

# ***Trace Heating Systems Serving Your Industrial and Domestic Requirements***

## **Self-Regulating Heating Tape Installation Manual**

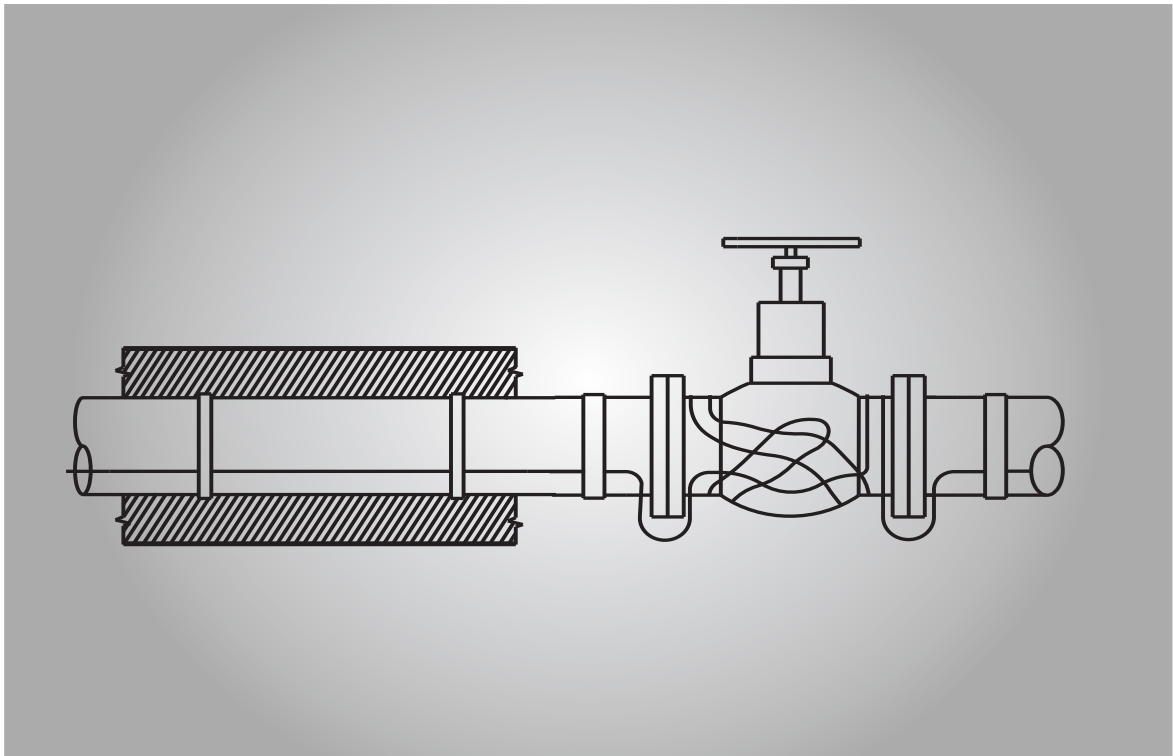

**For installation in safe  
and hazardous areas**

# Self-Regulating Heating Tape Installation Manual

---

## Receipt of Goods

After receipt of the goods check the heating tape and accessories for physical damages and compare with the data and amounts with the delivery note to ensure that the correct material has been supplied.

By hazardous area applications ensure that the corresponding approval certificates have been supplied.

## Warning!

All electric heat tracing systems must be installed correctly to ensure safe, proper operation and in order to prevent shock and fire. Read and follow these instructions carefully. Electrical equipment is to be installed only by qualified electricians.

Use a ground fault protection device (30mA) to minimize the danger of fire from sustained electrical arcing if the heating tape is damaged or improperly installed. Arcing may not be prevented using conventional style circuit breakers. When using the heating tape with braiding, this has to be connected to the potential earth. When using the tape without braiding, the heating system must be protected with a metallic covering. This metallic covering (eg. metallic covering of the thermal insulation) has to be connected to the potential earth. Local laws and regulations requiring the use of ground fault equipment protection for heating tape installations are to be followed at all times.

Measurements have to be taken on site to protect the braiding against physical or chemical damage by outdoor use of the heating tapes without outer protective overjacket. Ensure that the proper heating tape overjacket is chosen according to application, eg. chemical aggressive areas or UV protection by gutter heating.

Failure to properly install using the correct component kits or materials may cause arcing and fire. Do not use improper kits or substitute the materials. Do not use vinyl electrical tape or adhesive tape with emollients. Use only electrically specified termination, connection kits and installation materials, and follow the installation instructions supplied with them.

Damaged heating cable or components can cause electrical shock, arcing and fire. Do not attempt to repair or energize damaged heating tapes. Remove damaged sections at once and replace them with a new length of heating cable using the appropriate splice kit. Replace damaged components.

The black heating tape core within all styles of self-regulating heating tapes is electrically conductive and may short. The heating tape

core must be properly insulated and kept dry.

Damaged bus wires may overheat or short. Do not break bus wire strands when terminating the heating tape.

Do not use metal attachments such as pipe straps with sharp edges or tie wires that may cause damage to the heating tape during installation or in usage. Use only appropriate installation materials and cable ties to secure the heating cables to the pipe.

When using the heating tapes on metal surfaces, they also have to be protected against indirect contact according to local laws and standards before the system is taken into operation.

## Storage

The heating tapes and components have to be stored in a dry place at an ambient temperatures between  $-30$  and  $+60^{\circ}\text{C}$ . If a dry storage is not possible, the heating tape needs to be closed with an end termination set. This is also necessary if a heating circuit cannot be finished at the end of a shift. Do not store the materials in areas with a lot of traffic where potential damages may occur.

## Pre-Installation checks

### *General installation requirements*

Verify that the correct components and quantities are present with the selected heating tape and that there are no physical damages.

Verify that any paint or coatings used have dried.

Verify that the installation has been completed for surface to be heated.

Verify that the surface is clean of fats, sharp edges and burrs.

Plan the heating tape installation route on the surface to be heated.

Compare the design drawings and sketches with the actual surface to be heated.

Identify and mark the positions of the heating tape locations, according to design or max. heating tape length stated in the corresponding data sheet, and mark these with color spray paint or marker.

### *Pipeline installation*

Verify that the pipelines have been pressure-tested and that all appropriate equipment and supports have been installed.

# Self-Regulating Heating Tape Installation Manual

Compare the design drawings and sketches with the actual pipeline and note any differences in:

- pipe length and size
- number of valves, flanges, guages
- supports and other installation equipment.

**Note:** The max. allowable length of a heating circuit for unilateral feed depends on the admissible voltage drop. We recommend not to exceed a voltage drop of 10% and not to exceed 80% utilisation of the circuit breaker (with "C" characterisation).

## Heating tape installation on pipelines (and their respective components)

**Attention:** When installing heating tapes or cables on PVC, FRP or other forms of non metallic pipelines, the pipeline is to be completely covered using aluminium foil before installing the heating tape.

Mount the heating tape spool on a holder near either end of the pipeline to be traced. For installations that require two or more heating tapes, use two or more holders to pay out the heating tapes. Alternatively, using one spool, for installations that require two heating tapes, secure the end of the heating tape to the pipe and string one large loop along the length of the pipeline.

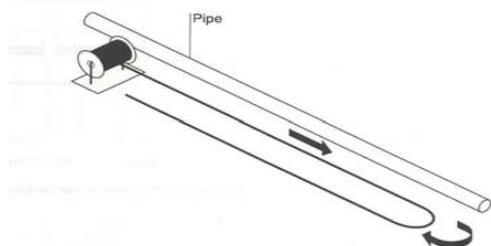

Do not apply excessive pulling or tension on the heating tape as it is being unrolled.

Pay out the heating tape and loosely string it along the pipe. Make sure that the heating tape is always next to the pipe when crossing obstacles. If the heating tape is on the wrong side of the obstacle (eg. a support beam, crossing pipe etc.) it may have to be removed and reinstalled or cut and spliced.

The heating tape may be straight traced along the pipe, spiral wrapped around the pipe or straight traced in multiple runs along the pipe, as required by the design.

**Note:** An overlapping during installation of the heating tape does not cause overheating due to the self-regulating heating characteristic. For further

information regarding self-regulating heating tape characteristics, please feel free to contact HTS or one of its representatives.

## Straight tracing

Whenever possible, position the heating tape or tapes on the lower section of pipe. This helps to protect the heating tape from mechanical damage during the installation, pre-insulation and insulation phases of the project.

Ensure that the maximal exposure temperatures of the the aluminium foil and glass cloth tapes used for securing and installation are within the maximal operation exposure ranges.

Starting from the end opposite to the heating tape spool and holder, secure the heating tape to the pipe using wraps of glass cloth tape at 0.3m intervals.

## Spiral Tracing

When the design calls for spiral tracing or wrapping of the heating tape on the pipe, begin by suspending a loop of heating tape for every 3.0m section of pipe.

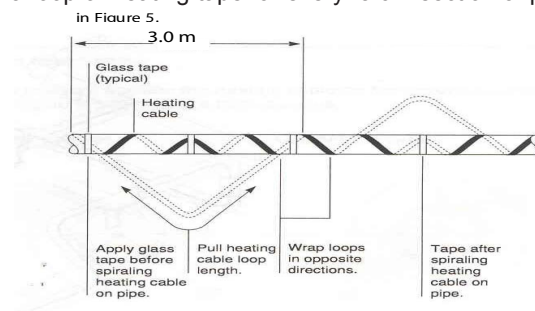

To determine the loop length, multiply the spiral factor from the drawing by ten (eg if the spiral factor is 1.3 leave a 4.0m loop of heating cable for every 3.0m of pipe). Pull the required amount of heating tape for the 3.0m section of pipe, attach the heating tape to the pipe at each end and let it hang in a loop. Grasp the loop in the center and wrap it around the pipe. Even out the distances between each spiral by sliding the wraps along the pipe. Use glass cloth tape at intervals to secure the loop to the pipe. Ensure that the heating tape is flat to the pipe for good heat transfer.

## Double or Multiple tracing runs

There are two design situations that dictate the use of two or more runs of heating tape on the pipe. These are:

- Critical processes sometimes require redundant heating circuits. In this type of design, heat sinks must be traced with both runs of heating tape.

# Self-Regulating Heating Tape Installation Manual

• Double or multiple runs of heating cable may be required to compensate for high heat losses that cannot be offset by the use of one cable. When using two or more spools of cable to supply runs to one pipe, it is important to take the extra cable required for tracing heat sinks from alternate spools. This will help to equalize the heating cable lengths in each circuit. Access loops should also be left on each heat sink that may require future service or maintenance.

The heating tape is recommended to be fully covered (the entire length) with aluminium foil, after securing with glass tape, in order to prevent insulation material slipping between the tape and surface to be heated. The usage of aluminium foil over the entire length also ensures a more effective heat transfer between the heating tape and the surface to be heated.

Work back towards the heating tape spool and holder, repeating the above procedure.

## Heating tape additions

Leave an extra 0.5m of heating tape at the power connection, at all sides of splices and tee splices and at the end seal location to provide sufficient heating tape to complete the required terminations.

Extra heating tape must be allowed and pulled for each heat sink (flange, pipe support, valve, instrument etc). The extra heating tape should be secured immediately before and after the heat sink and left in a loop. To obtain the required loop length for the type of heat sink being traced, consult Table 1.

## Termination

The connection and end termination of a heating circuit has to be carried out using approved materials and according to the termination instructions.

To avoid short circuit, do not connect the two bus wires of the heating tape with each other. Under all circumstances observe the termination and maintenance instructions for the connection and termination of the heating tapes.

Detailed installation instructions are supplied with each kit. Follow these instructions carefully when installing each kit. Before installing any kits, please consider the following important points:

- The black heating tape core is an electrically conductive heating matrix and can short. It must be properly insulated and kept dry.
- Damaged bus wires can overheat or short. Do not break bus wire strands when terminating the heating cable.
- Never connect or twist the heating cable bus wires together. This will cause a short.
- Failure to properly install the correct component kits can cause arcing and fire. Do not use other kits or substitute parts. Do not use vinyl electrical tape. Use only the specified termination and connection kits.
- Termination and connection kits should be positioned on top of the pipe when practical. Electrical conduit leading to power connection kits must have low-point drains installed to avoid condensation entry into the heating system. All heating cable connections must be mounted above grade.

Each heating circuit requires a minimum of one power connection box assembly and end seals for both ends of the heating cable. Splice kits and Tee splice kits are used as required. Consult the with your HTS representative to ensure that you have the correct component kits to meet your installation requirements.

**Hazardous Area applications:** Only termination material approved by a notified body may be used with the corresponding heating tape. The required air gap and cree distances are to be followed according to the corresponding termination instructions. An approved safety temperature limiter is to be used to limit the sheath temperature of the heating tape when a T3 rated self-regulating heating tape is used in a T4-T6 hazardous area.

**Attention:** Make sure that the heating tapes are never used at or exposed to temperatures above the

| Heating tape additions (m) for each: |     |      |      |      |     |      |     |     |     |     |     |     |     |     | Table 1 |     |
|--------------------------------------|-----|------|------|------|-----|------|-----|-----|-----|-----|-----|-----|-----|-----|---------|-----|
| DN                                   | 15  | 20   | 25   | 32   | 40  | 50   | 65  | 80  | 100 | 125 | 150 | 175 | 200 | 225 | 250     | 300 |
| Flange pair                          | 0,2 | 0,2  | 0,25 | 0,3  | 0,3 | 0,35 | 0,4 | 0,5 | 0,6 | 0,7 | 0,8 | 0,9 | 1,0 | 1,1 | 1,3     | 1,5 |
| Flanged components                   | 0,4 | 0,45 | 0,5  | 0,55 | 0,6 | 0,8  | 0,9 | 1,1 | 1,5 | 2,0 | 2,4 | 2,8 | 3,3 | 3,8 | 4,2     | 5,0 |
| Pumps                                | 1,5 | 1,5  | 2,0  | 2,0  | 2,5 | 2,5  | 3,0 | 4,0 | 5,0 | 5,0 | 6,0 | 6,0 | 6,5 | 6,5 | 7,0     | 8,0 |

For uninsulated pipe supports: 4 x support width x no. of supports = heating tape addition. For each junction box and thermostat add 0.5m heating tape. **Attention:** The above mentioned additions are to be made for each tracer.

# Self-Regulating Heating Tape Installation Manual

---

maximal exposure temperature ratings stated on the corresponding data sheet.

## Testing

A visual check of the heating tape regarding possible mechanical damages and/or incorrect installation.

Following the correct installation of the required kits, and before the pipe is insulated, it is important to apply an Insulation Resistance (IR) test to each heating circuit. Insulation Resistance testing is a reliable indicator of the electrical integrity of the heating circuit when all of the installation instructions are properly followed. Insulation Resistance Testing is more commonly known as "meggering". The following test must be completed on each heating circuit.

- As per ANSI IEEE Standard 141-1986, megger testing should be done at 500, 1,000 and 2,500 Vdc. Significant problems may not be detected if testing is only done at 500 or 1,000 volts.
- The megger test for braided versions of heating tapes should be conducted between the heating tape bus wires and the heating tape braid.
- The megger test for braided and overjacketed versions of heating tape requires the above test plus a second megger test taken between the heating tape braid and the pipe. All Insulation resistance values, independent of the heating circuit length, should be greater than 1,000 megohms. In case of a lower insulation resistance, the source of defect has to be determined and eliminated.
- Check of the function of the heat circuit (only in connection with the required temperature controller and/or limiter).
- Eventual damages must be repaired/replaced immediately. With short heating circuits, the heating tape may be replaced completely. With longer heating circuits, the defect is to be eliminated by cutting out the damaged part and replacing it by a new piece of heating tape according to the termination instructions.

**Hazardous Area applications:** test voltage 1460V for 1 minute.

Repeat the tests after applying the thermal insulation.

## Insulation entry

If the insulation is covered with a metal cladding, an insulation entry kit has to be used to avoid mechanical damage of the heating tape.

## Warning Labels

Electrically heated parts have to be identified in reasonable distances with warning labels "Electrical Heating" on the thermal insulation (approx. 5 m distance between each label on pipelines or at least 1 warning label per pipe branch respectively).

## Operation and Maintenance:

The local laws and regulations are to be followed according for the use of electrical heating tapes. The permissible operating specifications stated in the data sheets (i.e. voltage, amper-age, exposure temp., operating temp., IP protection classification) are to be followed accordingly.

Self-regulating heating tapes are generally maintenance free. It is however recommended that the heating tapes be checked by qualified personal in regular intervals for damages and insulation resistance.

The heating tape has to be protected against damages that may occur during repair work on heated components.

Damaged heating circuits may not be operated.

Temperature control units and control devices are to be checked at regular intervals by trained workers or authorized persons.

The heating circuit will once again need to be tested After completion of repairs

**Hazardous Area applications:** The opening of controllers, junction boxes and terminations are permitted only when the heating system is not under current.

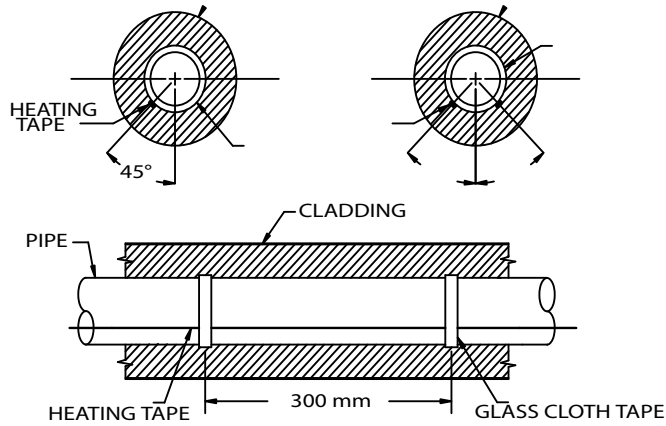

**Straight Traced Heating Tape**

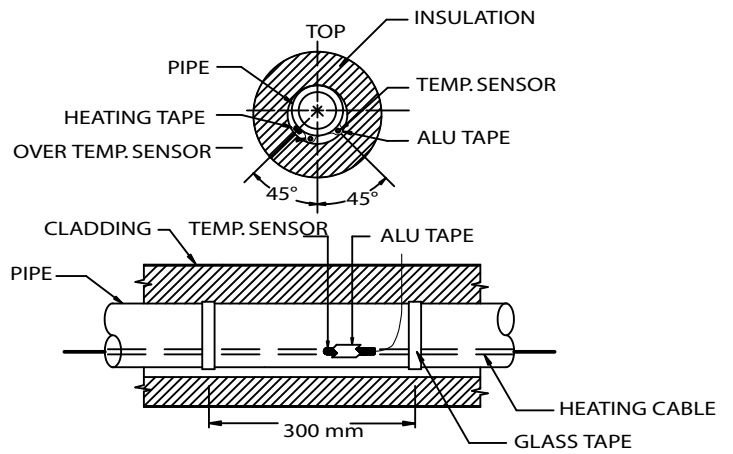

**Heating Tape Installation with pipe over temp. Cut-out and temp. sensor**

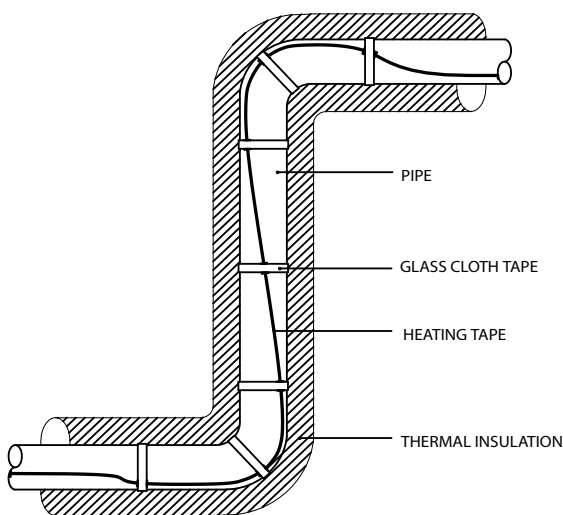

**Elbow Installation**

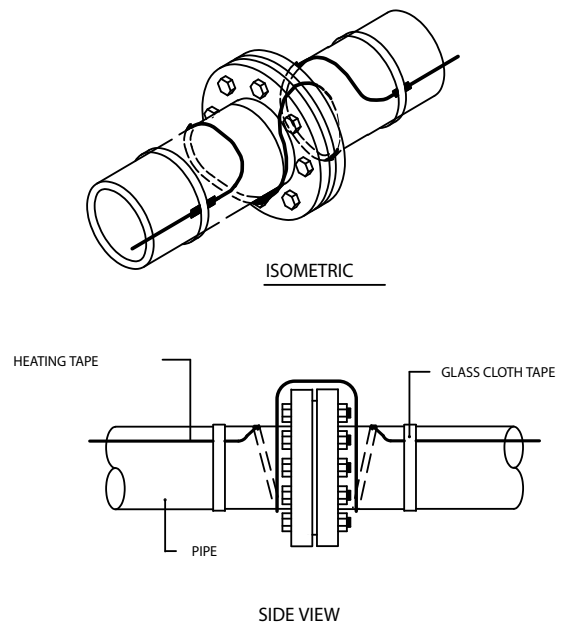

**Flange Installation**

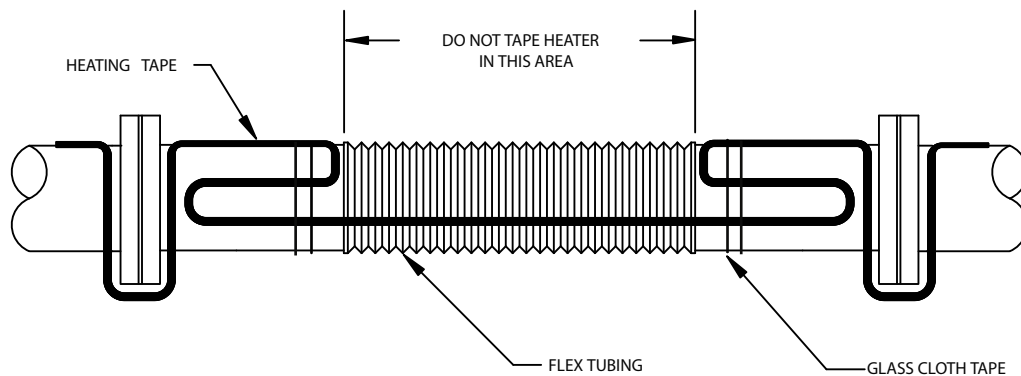

**Flex Tube Installation**

# Self-Regulating Heating Tape Installation Manual

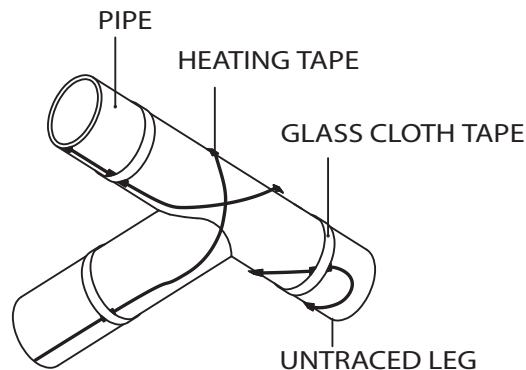
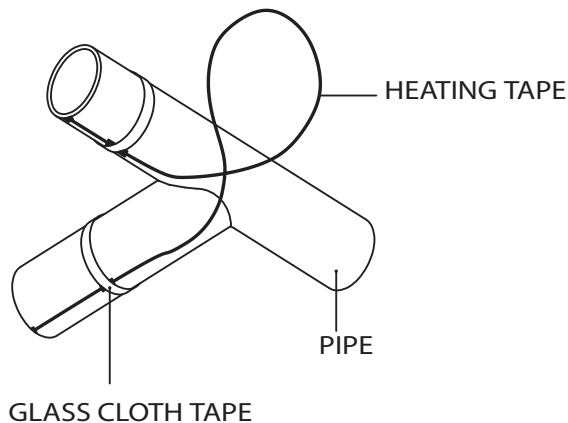

**Dead Leg Tee**

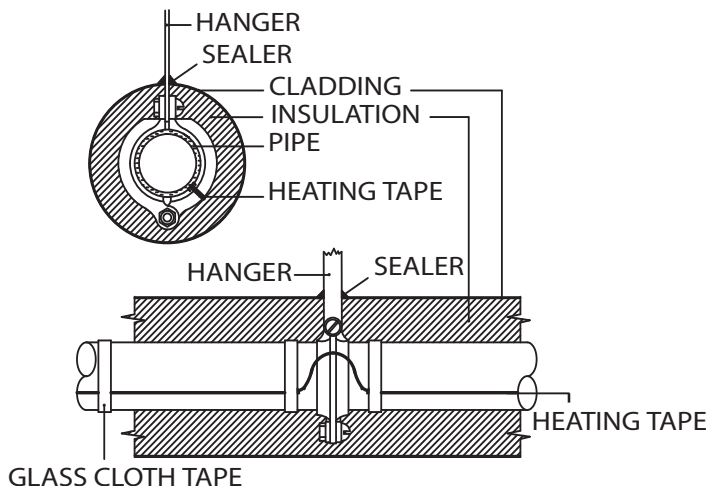

**Hanger Support**

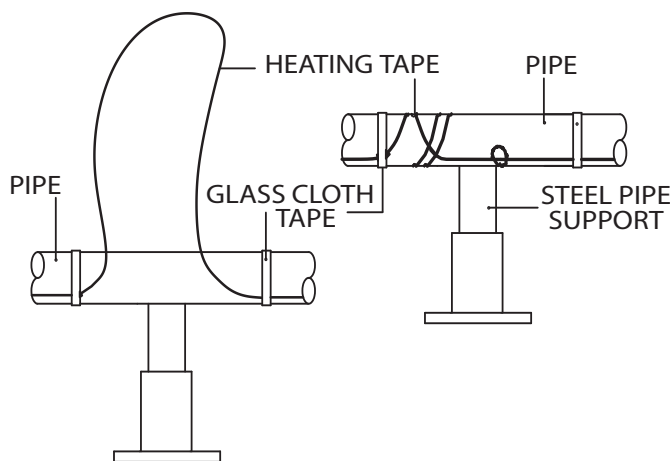

**Welded Pipe Support**

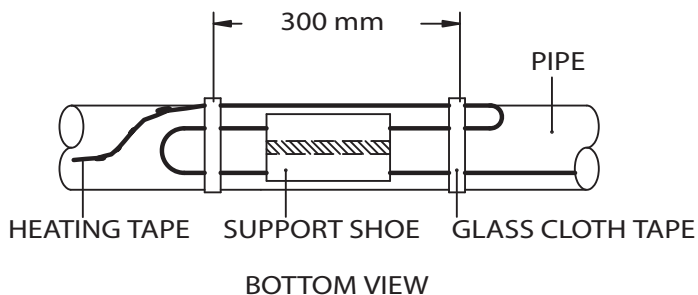
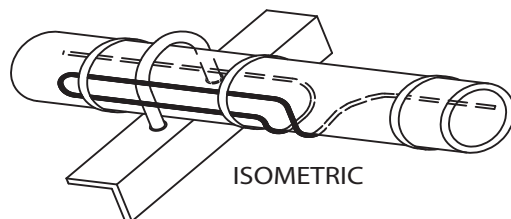

**Welded Pipe Support with shoe**

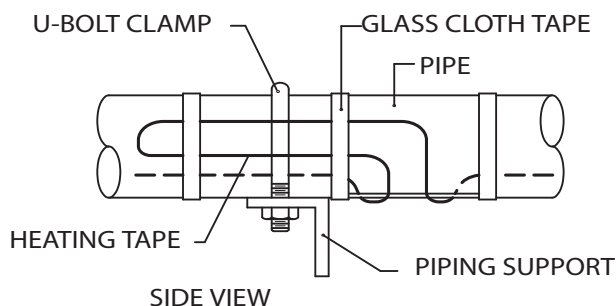

**U-bolt Pipe Support**

# Self-Regulating Heating Tape Installation Manual

